

PROCESSING
DRUM SCALPER
VA 900

GENERAL

Brand	Cimbria
Designation	Drum scalper
Model	VA 900
Use	Industry



The drum scalper is intended for separation of coarse impurities such as straws, strings, paper, splinters of wood, maize husks etc. from granular or mealy bulk products. Elimination of these impurities will exert a favorable effect on the functional reliability and performance of the machines and conveying elements of the processing line.

Mode of operation:

The products to be precleaned is fed into a screening cylinder through an amply dimensioned inlet piece. The product will drop through the screening cylinder whereas the coarse impurities will leave the machine as tailings.

The selection of the correct screen size (width of mesh) is of considerable importance for satisfactory precleaning results. The screening cylinder is available in different wire mesh sizes.

Before the product leaves the machine, dust and fines are removed with a cross flow aspiration.

High wear areas are covered with replaceable wear liners.

For easy observation of correct functioning, the machine is provided with detachable covers arranged on its rear side.

Technical data	
Rough cleaning*	
Wheat, barley	150 t/h
Maize	120 t/h
Rape seed	120 t/h
Sunflower seed	50 t/h
Soybeans	110 t/h
Paddy rice	50 t/h
Green coffee	50 t/h
Inlet	250x250 mm
Seed discharge	450x950 mm
Discard discharge	250x450 mm
Screen area	4 m ²
Motor:	1.5 kW
Total weight of the cleaner	500 kg
Freight volume	5.5 m ³

*Incoming product up to 10% impurities

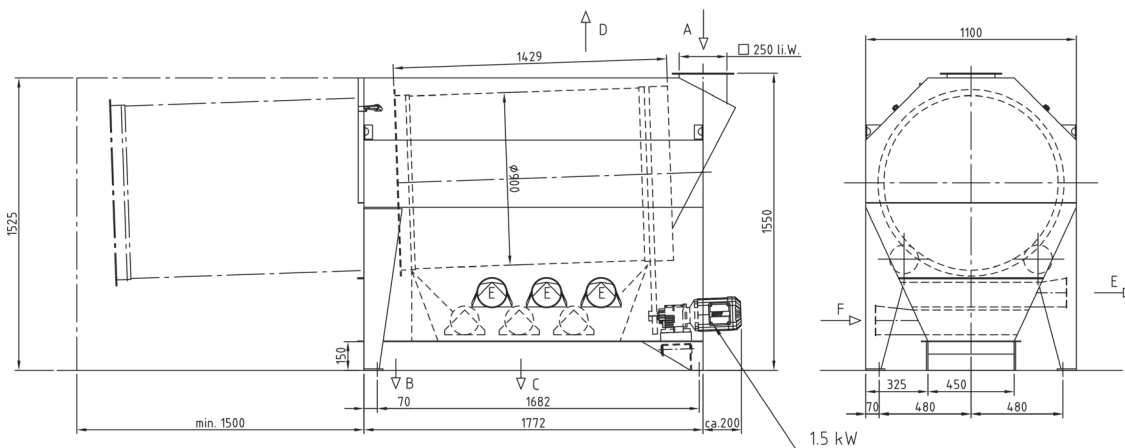
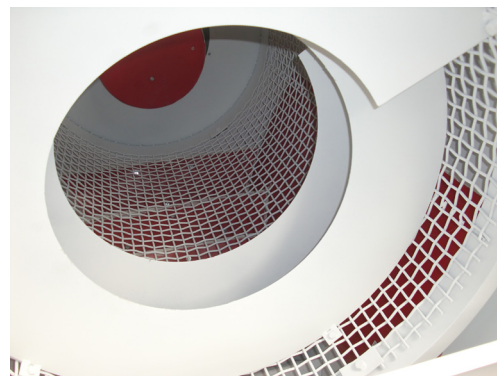

- A. Intake
- B. Tailings
- C. Throughs
- D. Aspirated air 20 m³/min.
- E. Aspirated air 3x14 = 42 m³/min.
- F. Air inlet