

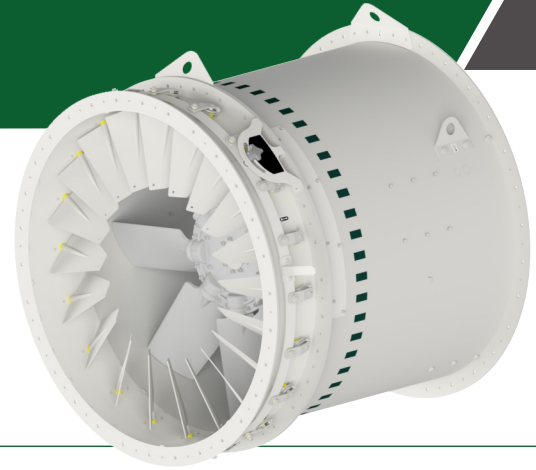

AXIAL FAN TYPE ARG-1150



GENERAL

Brand	Cimbria
Designation	Axial-flow fan
Model	ARG-1150
Use	Industry
Application	Moving air within a duct in large-volume dust collection systems

FAN CATEGORY

Casing construction	Welded/bolted
Drive arrangement	Direct drive
Inlet and outlet conditions	Inlet and outlet openings directly by the casing
Method of fan Control	Vane control (optional)
Outlet position	Horizontal or upward discharge
Motor position	Down-stream
Overall length, no guide vane	900 mm
Overall length, with vane	1 140 mm
Overall height	1 330 mm
Overall width	1 319 mm

EFFICIENCY

Efficiency grade	40
Measurement category	C
Efficiency category	Static
Efficiency*	50.4
Motor power input*	15.6 kW
Flow rate*	37 917 m ³ /h
Pressure	750 Pa
Efficiency**	60.8
Motor power input**	14.1 kW
Flow rate**	41 058 m ³ /h
Rotations per minute	1 475 rpm
Assumed drive type	Fixed
Specific ratio	0.995

** At operating point - $\rho = 1.135 \text{ kg/m}^3$

* At operating point - $\rho = 1.2 \text{ kg/m}^3$

Note: Efficiency calculated according to Commission Regulation (EU) 327/2011.

IMPELLER DATA

Impeller diameter	$\varnothing 115 \text{ mm}$
No. of blades	8
Pitch angle	23°
Blade type	6W
Blade material	PAG

WEIGHT

Weight, no guide vane	294 kg
Weight, with guide vane	376 kg

ELECTRICAL RATINGS

Motor output	15 kW
Motor voltage	400 V
Motor frequency	50 Hz
Motor ampere	29.01 A
Motor power factor	0.81
Motor efficiency	92.1 %

NOISE

Sound power level $L_w(C, out)^*$ 109 dB(A)

32 Hz	63 Hz	125 Hz	250 Hz	500 Hz	1k Hz	2k Hz	4k Hz	8k Hz
62	71	80	91	104	107	100	91	83

* Measured at 750Pa Static Pressure

Note: Noise calculated according to ISO 13347-3.

COMPLIANCE

EU machinery legislation	Yes
EU fan efficiency legislation	Yes
EU ATEX legislation	No
EU food contact legislation	No

ENVIRONMENTAL CONDITIONS

Environment	Indoors or outdoors
Temperature	From -20°C to +40°C
Altitude	Up to 1 000 m

SURFACE PROTECTION

Casing	Pre-galvanized
--------	----------------

LIFETIME

Intended life limit	20 years
---------------------	----------

PERFORMANCE

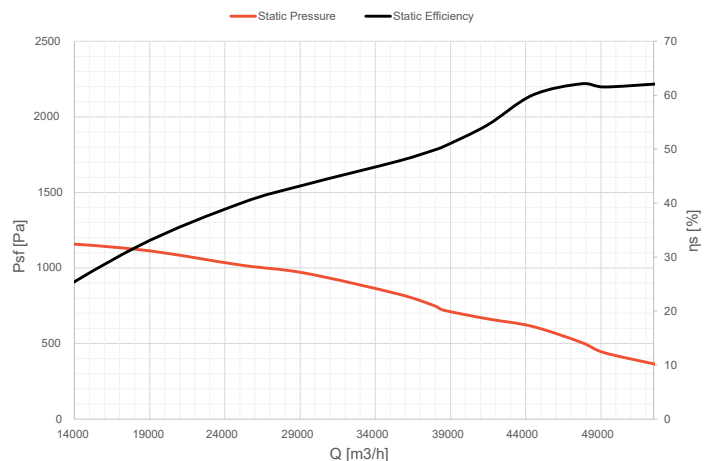

AXIAL FAN TYPE ARG-1150

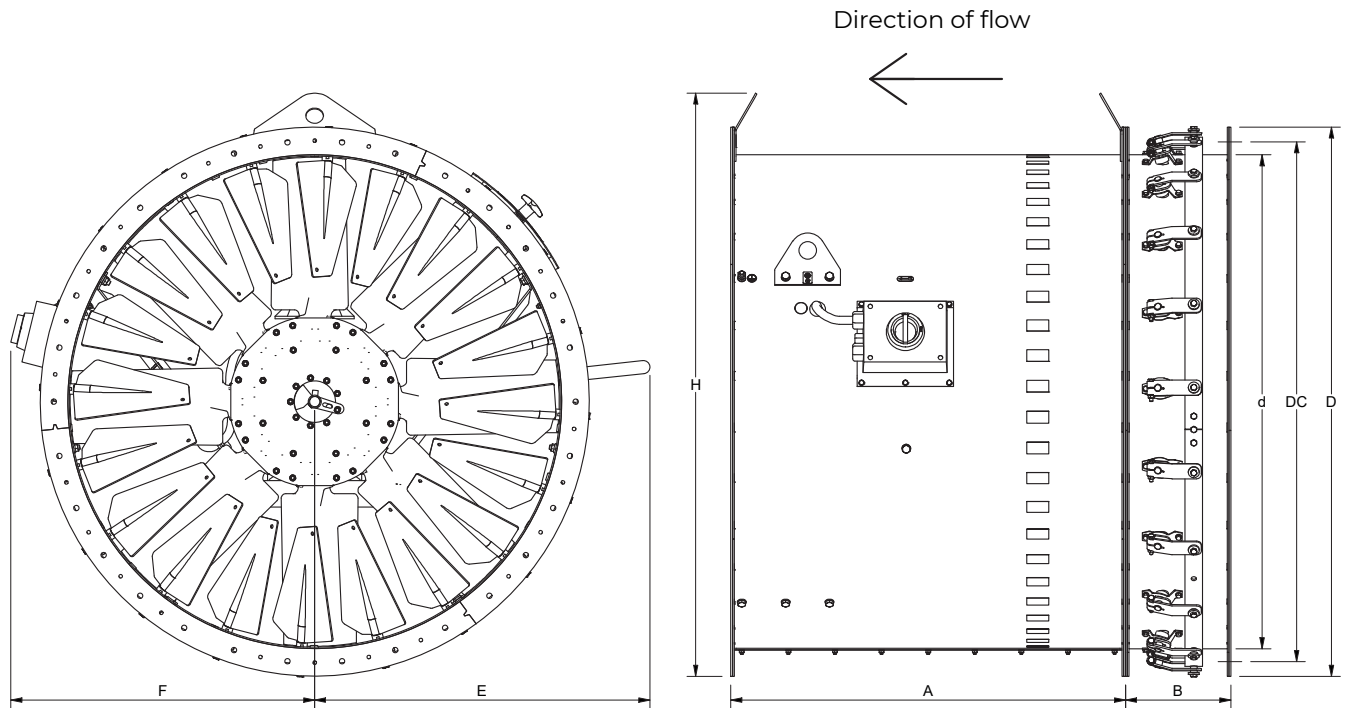

TECHNICAL DIMENSIONS

Fan	A	B	D	d	DC	E	F	H
ARG-1150	900	240	ø1 252	ø1 120	ø1 190 - 30xø12	764	693	1 330